



UNIVERSAL BOX BROODER

ASSEMBLY INSTRUCTIONS

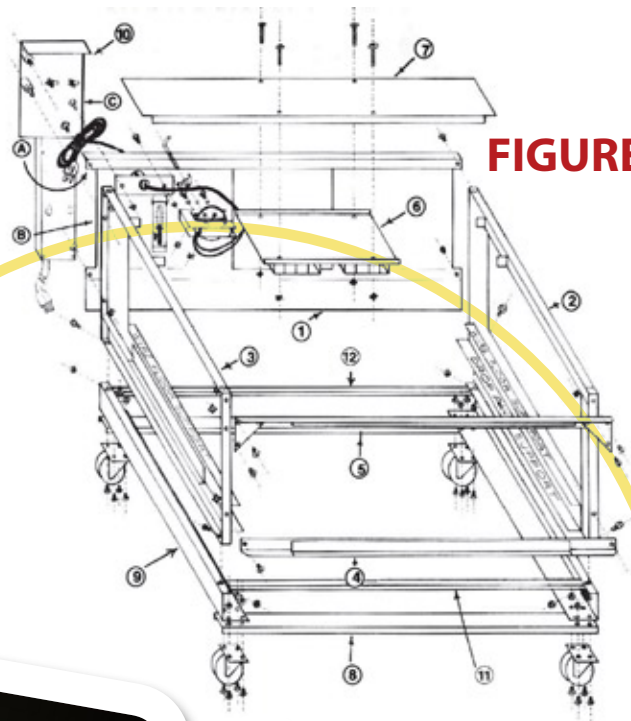

FIGURE 1

STEP 1



USE HARDWARE BAG. NO. 0569 FOR BROODER ASSEMBLY
Attach back panel (#1) to side frames (#2 & #3) with 3/8" Bolts
and Square Nuts as shown in Figure 1.

IMPORTANT! DO NOT TIGHTEN NUTS AND BOLTS UNTIL TOLD TO DO SO IN THESE INSTRUCTIONS. THEY MUST REMAIN LOOSE TO PERMIT FITTING OF ALL PARTS.

STEP 2

Attach front bottom Angle Bar (#4) with track facing up
and front top angle bar (#5) with triangle braces attached,
using 3/8" bolts and square nuts as shown in Figure 1.

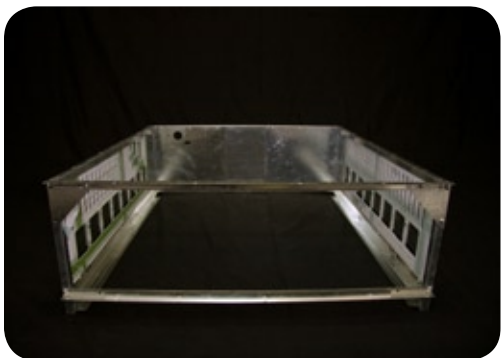

STEP 3



FITTING WIRE FLOOR IN BROODER - Insert the wire floor in through the front opening (over the top of part #4) and down into drop pan support rails. Press the brooder sides in or out to leave about 1/16" clearance between sides and the wire floor.

Tighten the 2 lower and the 2 upper back corner bolts. Then tighten the 2 lower front corner bolts (do not tighten the upper corner bolts at this time).

Raise the front of the wire floor and check for clearance when it is removed out over the front angle bar. If it binds, then adjust lower front corner bolts until the floor can be moved in and out through the front opening.

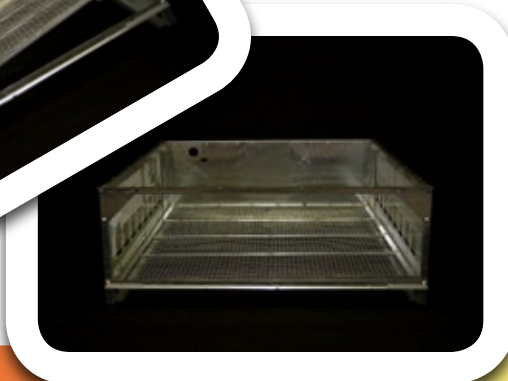

STEP 4

Insert the front and side sliding door panels in the tracks of angle bars that were installed in STEP 2. Hang troughs from the outer most slots of the panels.



Insert drop pan into bottom. Remove plastic wrap from door panels

SQUARING BROODER SIDES
Before tightening the top corner bolts, the front corner of the brooder sides must be squared. While the brooder is sitting on a flat surface, stand the drop pan up on edge and against front corner post (to serve as a square). Align brooder side with edge of the pan and tighten both front top bolts.

STEP 5



HEATER SUPPORT - Attach Heater (#6) inside the aluminum channel (#7) using 4 bolts 3/4" in length and square nuts. Tighten the bolts. Place aluminum support and heater between the brackets located on inside of the brooder sides. Put electric plug and cord through large hole on left side of back panel and attach with two 3/8" bolts and square nuts. Tighten them now.



STEP 6

MOUNTING THERMOSTAT - Put wing nut on adjusting screw (3" long with 90° bend one end). Just left of back door are 3 small holes. Insert the adjusting screw through the center hole of these 3 holes and screw it into the center hole of thermostat. Turn thermostat so that open side is towards door in back panel and attach with 2 bolts and nuts. Tighten bolts so adjusting screw is centered in the center hole. Screw wafer onto end of adjusting screw.

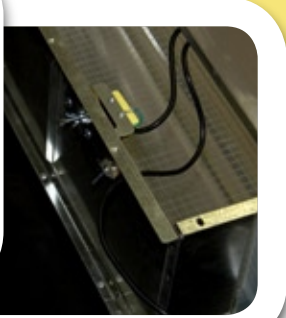
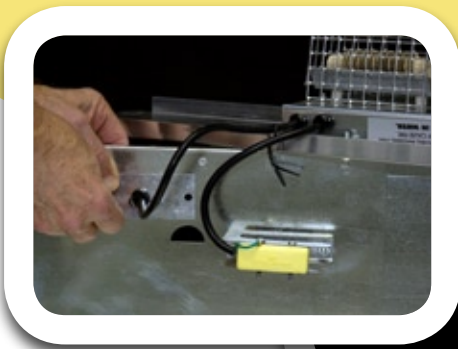

STEP 7

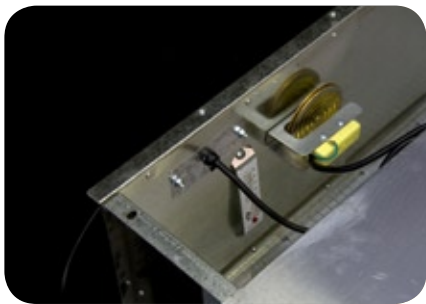

THERMOMETER AND THERMOSTAT - Insert thermometer through the half circle hole, between the thermostat and side of brooder. Purchase and install two 7 watt light bulbs in the 2 sockets on the heater. One light stays on all the time to serve as an attraction light. The other light turns on when the heater is on and turns off when the heater is off (this is to assist in regulating temperature). As the brooder heats, the wafer will expand depressing switch to turn the heat and light off. As It cools, the wafer will contract turning the heat and light on. Regulate to obtain the desired temperature.

OPERATING INSTRUCTIONS

Temperature

Brooders are designed to bring normal room temperature up to desired temperature. Brooders do not have sufficient heat to offset a cold, unheated barn. For game birds brooders should be regulated the first week to the temperature of the incubator, which is 100°F. Chickens and other larger birds can start at about 95°F. Lower the temperature setting 5° each week until a comfortable room temperature is reached.

Starting Chicks on Wire

The ½" mesh wire floor is designed to let droppings pass through to the drop pan. Smaller mesh wire soon begins to develop a mat of droppings on top of the wire which is not desirable. Day old chickens and larger chicks have no problem with ½" mesh flooring. Day old game birds such as quail, however, have difficulty for the first 5 days of age standing on ½" mesh flooring. For this reason it is recommend that a sheet of No 1628 DACB paper be placed on top of the wire for the first 5 days. DACB paper has been treated with antibiotics and can absorb moisture. If DACB paper is not available, paper towels may be used. Do not use slick cardboard or newspapers as day old chicks find this difficult to stand on. After the first 5 days the paper can be removed and the chicks can stand directly on the wire.

NOTE: The rate of growth of the chicks is related to the number of chicks in the brooder. Chick weight gain will not be as fast in a brooder filled to maximum capacity as compared to that of a chick in a half filled brooder.

Adjustable Gates

Adjust the gates on the sides of the brooder for the type of chicks to be brooded. Game birds such as quail will require that the gates be in the full down position for the first three weeks. During this time the troughs will not be needed for game birds and maybe removed. After three weeks the troughs may be installed (see warning below) and the gates adjusted up to the first marking hole (see picture) on the plastic side panel. Monitor the chicks to see that they are feeding properly and do not get out. Adjust size of gap to suit the chicks and remember to raise the gates every week or two, as birds get older. Chickens and other large chicks may start with the gates set at the second to third marking hole up from the bottom on the plastic panel (see picture). Monitor the chicks to see that they are feeding properly and do not get out. Adjust size of gap to suit the chicks and remember to raise the gates every week or two, as birds get older.

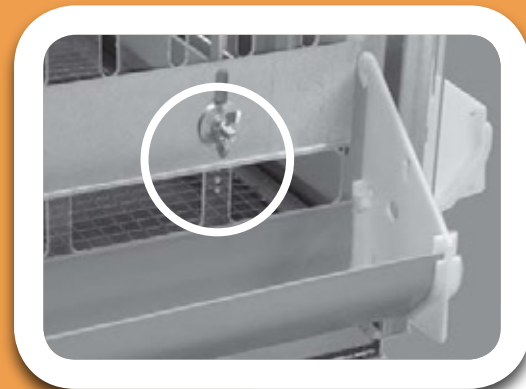

Feed and Water

Game birds are too small to feed out of the troughs for the first 3 weeks so small feeders and drinkers must be placed inside of the brooders. The 5003 box feeder and the 4458 drown proof quail waterer is designed for this purpose. Any feeders and waterers of this type may be used. Trays of feed and shallow pans of water with rock or marbles in it (do not fill water above the marbles) may be used as well but will require more attention. After 3 weeks of age the game bird chicks should be of sufficient size to feed from the troughs. Chickens and other larger chicks can be started directly from the troughs. All troughs are capable of holding water, but usually only one is filled with water and the other two with feed. Optional float valves can be added to the troughs for automatic watering. This brooder is designed for ample feed and water space for a full brooder of chicks.

WARNING: Test to be sure that small chicks can reach a small amount of feed in bottom of trough. If they cannot, it will be necessary to keep the feed and water trough at least half full until they are larger or they could starve to death.

Cleaning

Drop pans are easily removed from the front of the brooder to dispose of droppings and debris. Pans can be lined with No. 1628 DACB paper to control odors or line the pans with newspaper or other absorptive material for easy cleaning. The clear side panels can be wiped with a damp cloth or placed in a dishwasher. Floors, drop pans, sides, troughs and tops can be cleaned with warm soapy water and placed in strong sun light to dry. Heat elements and thermostats should not be wet or immersed in water but maybe wiped with a damp cloth with disinfectant when not plugged into power.

VIEWABLE EXPANDER (OPTIONAL)

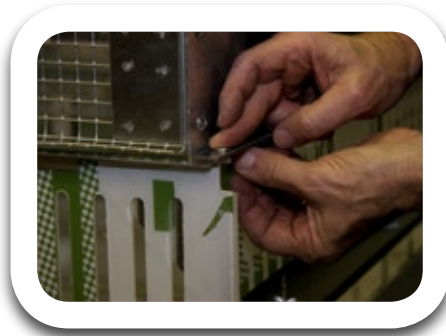
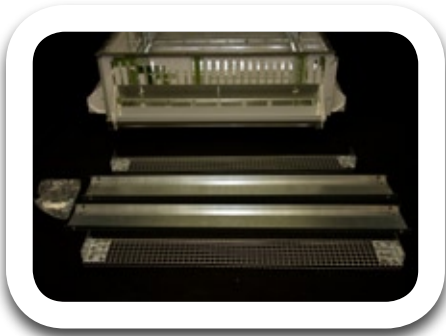

Start with one corner of the expander, attaching one sheet metal side to one wire mesh side. Leave screw finger tight. Next, attach the second sheet metal side across from the first., then complete the square with the second wire mesh side. Set the expander on top of the brooder and attach with screws. Tighten all hardware and place brooder's original top panels on top.

BROODER BASE (OPTIONAL)

Study the exploded drawing of brooder base (Figure 1) which is shown right side up. Study the corner detail which is shown upside down in Figure 2. The BROODER BASE MUST BE ASSEMBLED UPSIDE DOWN. Using bag No. 0570 of 3/8" Oval Head Bolts and HEX NUTS, assemble each corner of Brooder Base as shown in Figure 2, hand tighten only until after mounting to the brooder. HARDWARE BAG. NO. 0570 FOR BROODER BASE ASSEMBLY.



MOUNTING AND STACKING BROODERS ON BROODER BASE - Use bag No. 0571 HEX NUTS AND 3/8" OVAL HEAD BOLTS. Place brooder base on a flat surface in UPRIGHT POSITION. Remove brooder lids, wire floor and dropping pan from assembled brooders. Place assembled brooder on the base and align the slotted holes in top of the base with slotted holes in the bottom of the brooder. Put 3/8" OVAL HEAD BOLT through 4 slotted holes. Slip one end of brooder base support, (#11 or #12) over one of these bolts and hold with hex nut. After mounting both supports in this manner, tighten all four nuts. NOW TIGHTEN NUTS AND BOLTS ON ALL 4 CORNERS OF THE BROODER BASE. This job will be easier if brooder and base are turned on its side.

STACKING BROODERS TO MAKE A BATTERY - Place an assembled brooder onto the brooder that is mounted to the brooder base. Align the slotted holes in the top rail of the brooder with the slotted holes in the bottom rail of the brooder. Put a 3/8" OVAL HEAD BOLT through 4 slotted holes and secure with HEX NUTS and TIGHTEN ALL 4 OF THE BOLTS. Repeat this process for each brooder stacked. DO NOT STACK OVER 5 HIGH. =Place 2 lids on top brooder only. HARDWARE BAG NO. 0571 FOR STACKING BROODERS.

MOUNTING PLUG STRIP TO BROODER (#10) - Remove bolt "A" (Figure 1) from back left corner of brooder. On the back of the Plug Strip are 2 bolts with 2 nuts on each bolt. Remove one nut from each bolt on the plug strip. Insert the bolts on the plug strip into holes "A" and "B", Figure 1. Put the 2 nuts that were removed, back onto the bolts and tighten them. When used on a Battery, the Plug Strip should be mounted on the second or third brooder, so all electric plugs can reach the Plug Strip.

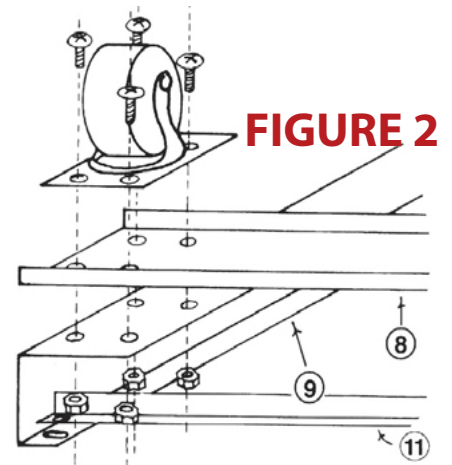

LIMITED WARRANTY AND RESTRICTIONS

GQF Manufacturing Co., Inc. guarantees against defect for a period of 1 year from date of purchase. This warranty is void for product more than 3 years old when not sold direct from GQF to the consumer. Notify GQF Mfg. Co. of any defective items, giving catalogue number and name of item and what is wrong with item. Send copy of invoice showing date of purchase. GQF Mfg. Co. will send replacement, or replacement parts, or notify regarding return. Shipping charges for express shipping or shipments outside of the continental USA are to be paid by the customer. Product being used outside of the continental USA may need to be returned to GQF at user's expense for warranty work. Returning of items without written permission will be at owner's expense.

Whereas GQF Mfg. Co. has no control over usage of equipment and product supplied, it assumes no responsibility for losses or damage from the equipment or product other than replacement of defective parts. No guarantee on hatchability of eggs. GQF assumes no responsibility for losses due to shipping damage, late shipment or arrival of product.

Do not expose electrical parts to water. Installation of electrical parts should be done by a qualified electrician. Use of replacement parts other than intended by GQF Mfg. Co. is not permitted. GQF not responsible if product does not comply with local product codes or codes outside of the USA.

G.Q.F. MANUFACTURING COMPANY

Phone 912-236-0651 P.O. Box 1552 - Savannah, GA 31402 www.GQFMFG.com